

# Chauffage à eau

## Water heater

### AK Ø112

- Aérotherme à circulation d'eau, pour souffler dans une gaine Ø112mm
- Vanne intégrée avec raccordement rapide pour commande à câble
- *Water heat exchanger with a Ø112mm duct outlet*
- *Integrated valve for a quick connection for cable control*

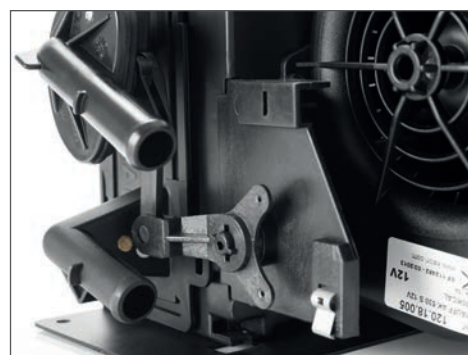
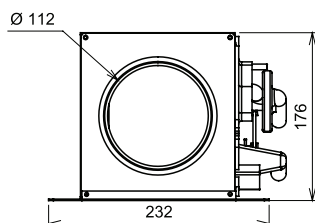
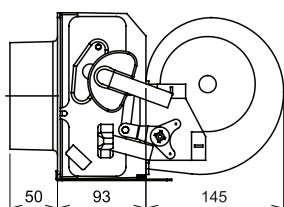
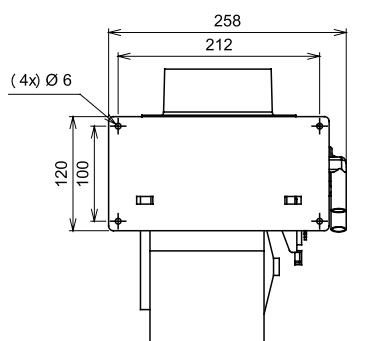

Puissance de chauffe / Heating power	6 kW
Débit d'air / Airflow	350 m³/h
Consommation électrique / Electrical consumption	205 W
Raccord eau / Water fitting	Ø 16 mm
Niveau sonore / Noise level	65 dB
Vitesse de ventilation / Ventilation speed	3

Tension / Voltage	Reference
12 V	120.18.016
24 V	120.18.116

CHAUFFAGE • HEATING